

DECKMA GmbH

Decksmaschinen und Automation Vertriebs GmbH

Fon: +49 (0)4105 - 65 60-0 · Fax: +49 (0)4105 - 65 60-25 · Web: www.deckma-gmbh.de · E-Mail: info@deckma-gmbh.de

Vorschaltgerät HPS-MH / Ballast Unit HPS-MH

DE-GIBA 250 HPS/MH

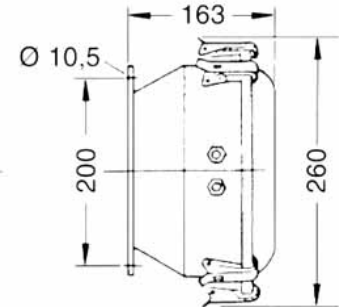
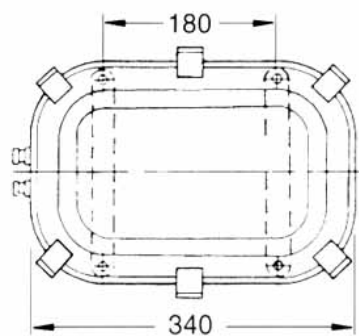

Materialien	Edelstahl Gehäuse, weiss pulverbeschichtet. Edelstahlverschlüsse, rostfrei. Unverlierbarer Deckel. Kabelverschraubungen aus Messing.	Materials	Body of stainless steel, white powder finish. Stainless steel locking clamps. Lid attached to the body. Cable glands of brass.	
Kabeleinführung	2 Kabelverschraubungen M24x1,5 MGCG	Cable entry	2 Cable glands M24x1,5 MGCG	
Gewicht	7,5 kg	Weight	7,5 kg	
Schutzart	IP 67	Protection class	IP 67	
Anschluss	3-Fach Terminalblock für je 2 x 6 qmm	Connection	3-way 2 x 6 sq.mm terminal block	
Befestigung	4 Schrauben M10	Mounting	4 screws M10	
Spannung	220V AC 230V AC	Voltage	220V AC 230V AC	
Type	Merkmale	Features	Best. Nr / Order No	
DE-GIBA 250W HPS/MH	Externes Vorschaltgerät für 250W HPS/MH Strahler	External ballast for 250W HPS/MH floodlight	50 Hz	000-392
			60 Hz	000-393