

DECKMA GmbH

Decksmaschinen und Automation Vertriebs GmbH

Fon: +49 (0)4105 - 65 60-0 · Fax: +49 (0)4105 - 65 60-25 · Web: www.deckma-gmbh.de · E-Mail: info@deckma-gmbh.de

Vorschaltgerät HPS-MH / Ballast Unit HPS-MH

DE-GIBA 400 HPS/MH

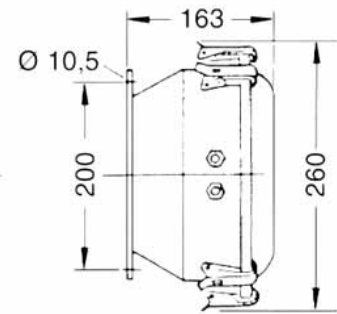
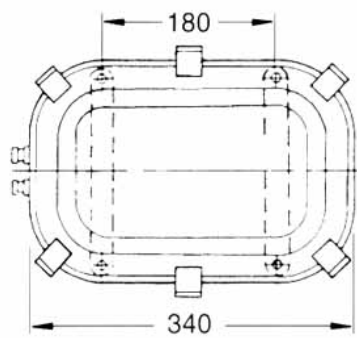

Materialien	Edelstahl Gehäuse, weiss pulverbeschichtet. Edelstahlverschlüsse, rostfrei. Unverlierbarer Deckel. Kabelverschraubungen aus Messing.	Materials	Body of stainless steel, white powder finish. Stainless steel locking clamps. Lid attached to the body. Cable glands of brass.
Kabeleinführung	2 Kabelverschraubungen M24x1,5 MGCG	Cable entry	2 Cable glands M24x1,5 MGCG
Gewicht	8,5 kg	Weight	8,5 kg
Schutzart	IP 67	Protection class	IP 67
Anschluss	3-Fach Terminalblock für je 2 x 6 qmm	Connection	3-way 2 x 6 sq.mm terminal block
Befestigung	4 Schrauben M10	Mounting	4 screws M10
Spannung	220V AC 230V AC	Voltage	220V AC 230V AC

Type	Merkmale	Features	Best. Nr / Order No	
DE-GIBA 400W HPS	Externes Vorschaltgerät für 400W HPS Strahler	External ballast for 400W HPS floodlight	50 Hz	000-395
			60 Hz	000-396
DE-GIBA 400W MH	Externes Vorschaltgerät für 400W MH Strahler	External ballast for 400W MH floodlight	50 Hz	000-398
			60 Hz	000-399